

DWG BY: CRB	DATE: 10/29/08	TOLERANCE UNLESS OTHERWISE SPECIFIED	
		.X = ± .063 ANGULAR	+ 1.0°
		.XX = ± .032 HOLE DIA	
		.XXX = ± .015	± .005
SHEL-LAB SHELDON MANUFACTURING CORNELIUS, OREGON		SCALE: 1:10	NOTE BEND RADIUS .032" UNLESS OTHERWISE NOTED
OVEN 3CF GRAVITY		PART#: 9071294	REVISION
		MATERIAL	

CHG BY	CHG NR	REV	DATE	DESCRIPTION
--------	--------	-----	------	-------------

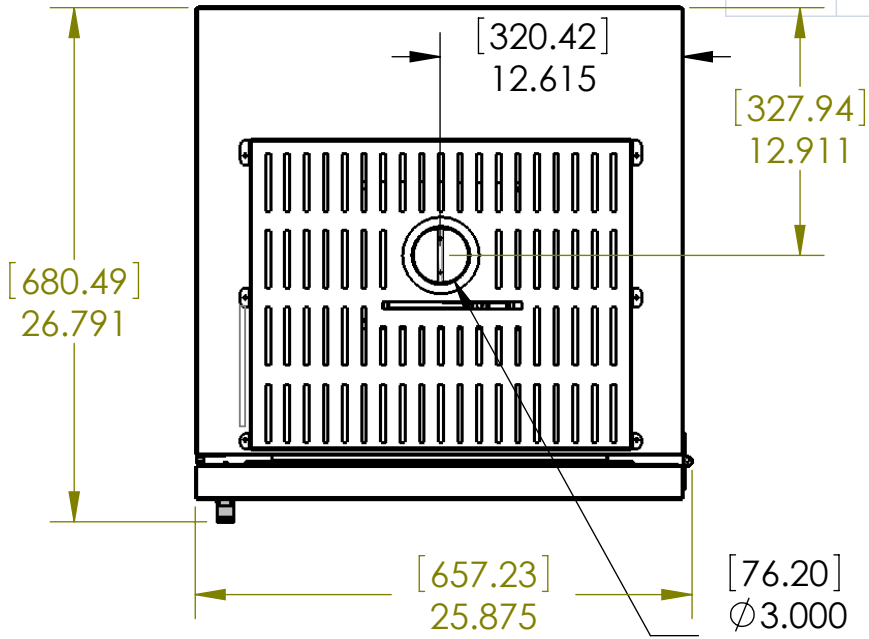

[76.20]
Ø3.000
EXHAUST
DAMPER

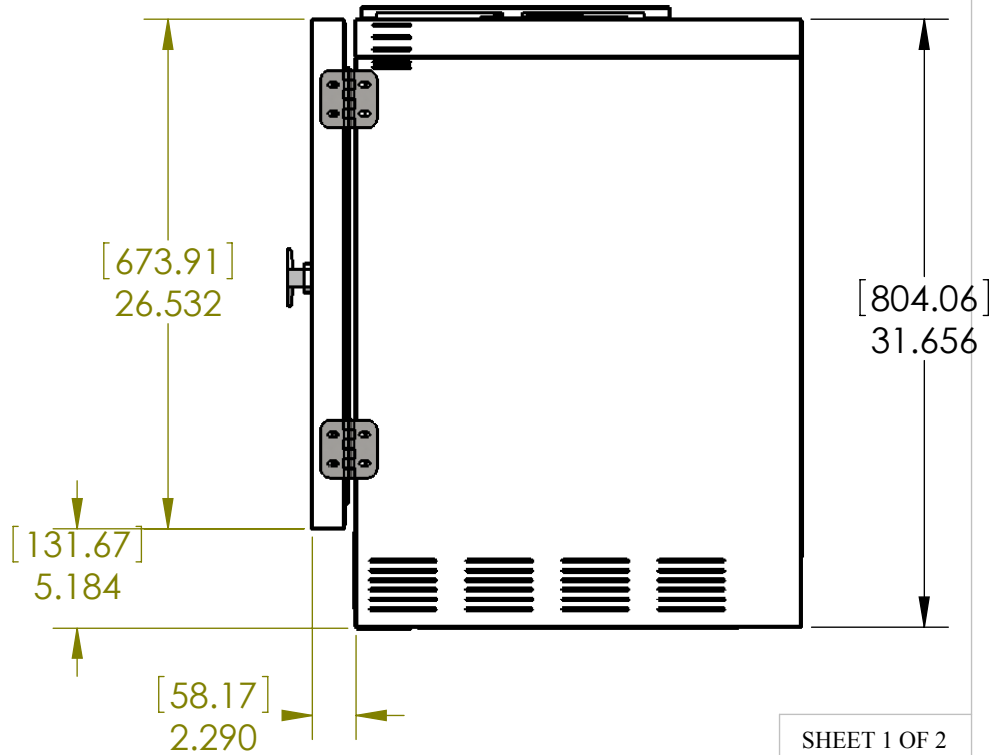
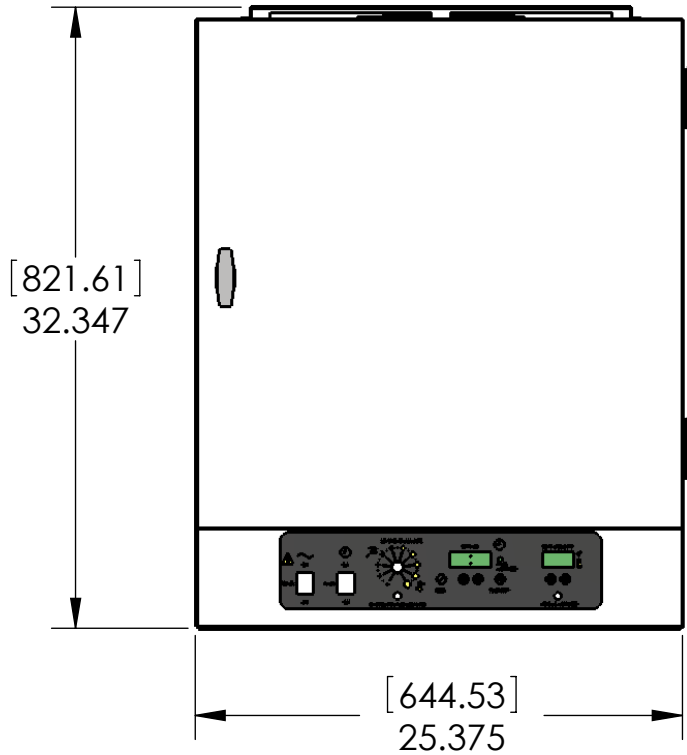

DWG CRB DATE

BY:
 TOLERANCE UNLESS OTHERWISE SPECIFIED
 .X = ± .063 ANGULAR
 .XX = ± .032 HOLE DIA
 .XXX = ± .015 ± .005

SHEL-LAB

SHELDON MANUFACTURING CORNELIUS, OREGON

LINER INTERIOR DIMENSIONS

SCALE: 1:8

PART# 9071294

MATERIAL

NOTE
 BEND RADIUS .032"
 UNLESS OTHERWISE NOTED

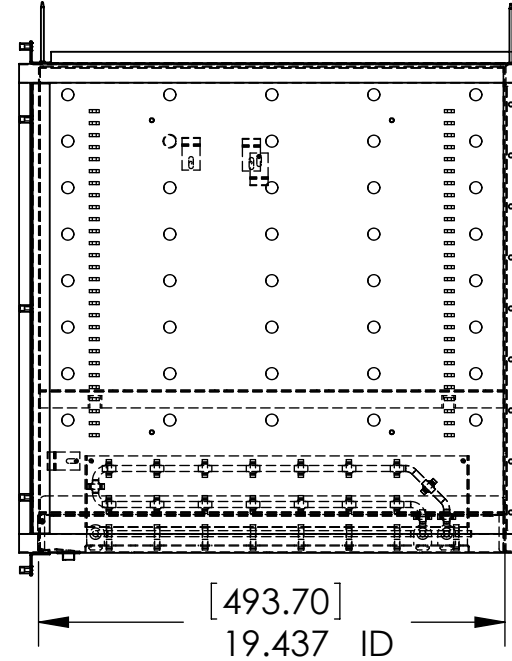
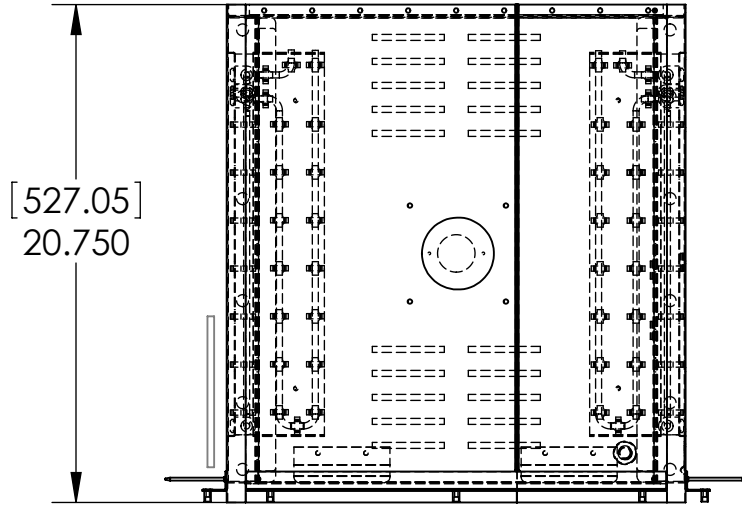
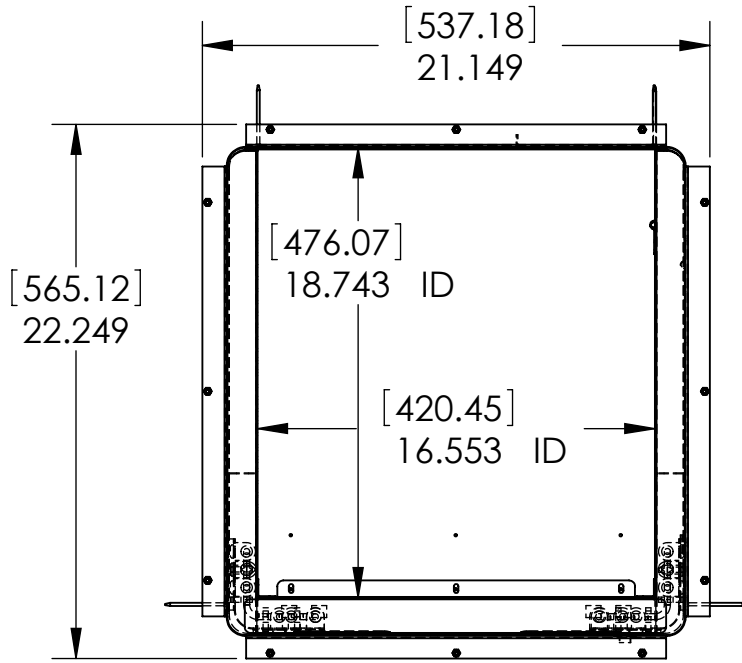

CHG. BY	CHG. #	REV.	DATE	DESCRIPTION