

Installation  
Operation  
and  
Maintenance  
Instructions

Hazardous Location Models

**4EAF** Freezer

**6EAR** Refrigerator

**6ERF** Combination Refrigerator / Freezer



# CONTENTS

Unpacking your refrigerator .....	3
Removing the packaging .....	3
Warranty registration .....	3
Installing your refrigerator .....	4
Select location .....	4
Installation .....	4
Cabinet clearances .....	4
Leveling legs .....	4
Electrical Connection .....	4
Wiring .....	4
Sealing .....	4
Handle installation .....	5
Door alignment .....	5
Dimensions for 4EAF, 6EAR, 6ERF .....	6
Rough in opening dimensions for 4EAF, 6EAR, 6ERF .....	6
Adjusting the temperature control.....	7
Defrosting instructions .....	7
Energy Saving Tips .....	7
Care and Cleaning .....	8
Trouble shooting your refrigerator .....	9
Obtaining service .....	10
Commercial product warranty .....	11

## Important Safety Instructions

Warnings and safety instructions appearing in this guide are not meant to cover all possible conditions and situations that may occur. Common sense, caution, and care must be exercised when installing, maintaining, or operating this appliance.

## Recognize Safety Symbols, Words, and Labels.

### **CAUTION**

**CAUTION**-Hazards or unsafe practices which could result in personal injury or property or product damage.

### **WARNING**

**WARNING**-Hazards or unsafe practices which could result in personal injury.

### **NOTE**

**NOTE**-Important information to make a problem free installation.



**AGA MARVEL** is committed to building a quality product in an environmentally friendly manner. Our processes are tightly controlled and closely monitored. We have achieved certifications in ISO 9001 for quality assurance, ISO 14001 for environmental management, and OHSAS 18001 for occupational health and safety from Lloyd's Register Quality Assurance.

# UNPACKING YOUR REFRIGERATOR

---

## Remove Packaging

Your refrigerator has been packed for shipment with all parts that could be damaged by movement securely fastened. Cut the banding material at the bottom of the carton, unfold the carton at the bottom and remove the carton from the appliance. Remove the plastic bag, styrofoam corner posts, and any tape holding the door closed and internal components in place. The owners manual is shipped inside the refrigerator in a plastic bag along with the warranty registration card.

## Important

Keep your carton packaging until your refrigerator has been thoroughly inspected and found to be in good condition. If there is damage, the packaging will be needed as proof of damage in transit. Afterwards please dispose of all items responsibly in particular the plastic bags which can be a suffocation hazard.

## Note to Customer

This merchandise was carefully packed and thoroughly inspected before leaving our plant. Responsibility for its safe delivery was assumed by the retailer upon acceptance of the shipment. Claims for loss or damage sustained in transit must be made to the retailer.

DO NOT RETURN DAMAGED MERCHANDISE TO THE MANUFACTURER - FILE THE CLAIM WITH THE RETAILER.

## NOTE

If the unit was shipped or has been laying on its back for any period of time allow the refrigerator to sit upright for a period of at least 24 hours before plugging in. This will assure oil returns to the compressor. Plugging the refrigerator in immediately may cause damage to internal parts.

## Warranty Registration

It is important you send in your warranty registration card immediately after taking delivery of your refrigerator or you can register online at [www.agamarvel.com](http://www.agamarvel.com).

The following information will be required when registering your unit.

Model Number  
Serial Number  
Date of Purchase  
Dealer's name and address

The model number and serial number can be found on the serial plate which is located inside the cabinet on the left side near the top.

## CAUTION

### Help Prevent Tragedies

Child entrapment and suffocation are not problems of the past. Junked or abandoned refrigerators are still dangerous, even if they sit out for "just a few days".

If you are getting rid of your old refrigerator, please follow the instructions below to help prevent accidents.

Before you throw away your old refrigerator or freezer:

- Take off the doors or remove the drawers.
- Leave the shelves in place so children may not easily climb inside.

# INSTALLING YOUR REFRIGERATOR

These refrigerators and freezers have been engineered for institutional and industrial hazardous locations and meet Underwriters Laboratories specifications for Class 1 Groups C and D. Approved by the New York City Board of Standards and Appeals under Calendar Number 496-80-SA.

## Select Location

The proper location will ensure peak performance of your appliance. Choose a location where the unit will be out of direct sunlight and away from heat sources.

The condenser is mounted on the back of the cabinet so the unit cannot be built in. At least 1-1/2 inches (3.8cm) of clearance from the back wall is required for proper ventilation.

## Installation

The 4.5 and 6.1 cu. ft. refrigerators are designed for recessed as well as freestanding installation.

To recess the 4.5 and 6.1 cu. ft. models make the opening 25-7/8" (657.4mm) wide x 35-3/4" (908.1mm) high x 27-1/2" (698.5mm) deep with ample provision for wiring as described in the following paragraph "Sealing" instructions. Other service information can be found on pages 8 and 9. Provisions should be made to easily remove the unit for servicing.

Do not back the unit up to heat ducts or hot water lines.

## Cabinet Clearance

Ventilation is required from the bottom front section of the unit. Keep this area open and clear of any obstructions.

## Leveling Legs

Adjustable legs at the front and rear corners of the unit should be set so the unit is firmly positioned on the floor and level from side to side and front to back. Turn leveling legs clockwise to raise unit, counterclockwise to lower it. (See Figure 1).

## Electrical Connection

Check serial plate for correct power supply. Use only electrical power supply as specified on your appliance serial plate.

## Wiring

Hazardous location models are not supplied with power cords or plugs. All wiring methods must comply with the latest National Electrical Code, Article 501-4 for Class 1, Divisions 1 and 2.

## Sealing

Article 501-5 of the National Electrical Code Class 1, Division 1 requires that in Class 1 Division 1 locations, seals shall be located as follows:

In each conduit run entering an enclosure for switches, circuit breakers, fuses, relays, resistors, or other apparatus which may produce arcs, sparks, or high temperatures, seals shall be placed as close as practicable and in no case more than 18" (45.7cm) for such enclosures.

## ⚠ CAUTION

### Front Grille

Do not obstruct the front grill. The openings within the front grill allow air to flow through the condenser heat exchanger. Restrictions to this air flow will result in increased energy usage and loss of cooling capacity. For this reason it is important this area to not be obstructed and the grill openings kept clean. AGA MARVEL does not recommend the use of custom made grills as air flow may be restricted because of inadequate openings. (See Figure 1).

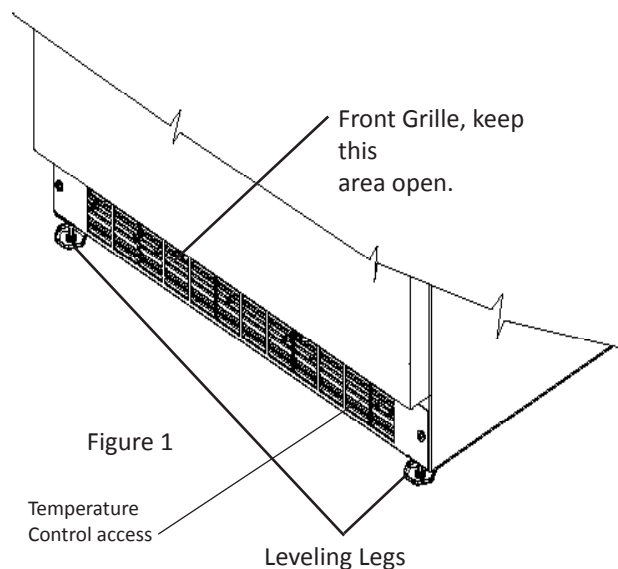

# HANDLE INSTALLATION

## Handle Installation

1. Remove the handle, (2) screws, and 5/32" hex key wrench from the bag shipped inside the cabinet.
2. Locate handle opposite the hinges and secure in place using the (2) screws and the hex key wrench. (See Figure 2).

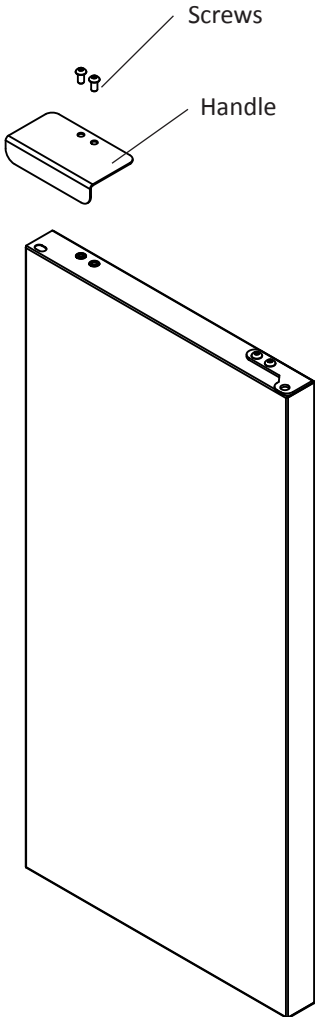

Figure 2  
Right hand hinged  
door shown

## Step 1: Verify door alignment

The door should be parallel to the sides and top of the refrigerator. If alignment is necessary the door may be adjusted by loosening the 2 screws which secure the hinge adapter brackets on the top and bottom of the door and adjusting the door side to side. Use a 5/32" allen wrench for this procedure. (See Figure 3 below). When finished aligning the door, tighten the screws securely.

## NOTE

For the door to close properly, it is necessary to maintain a minimum space of 9/32" (7mm) between the door and cabinet flange (See Figure 3). This space can be adjusted by adjusting the top and bottom hinge adapter brackets.

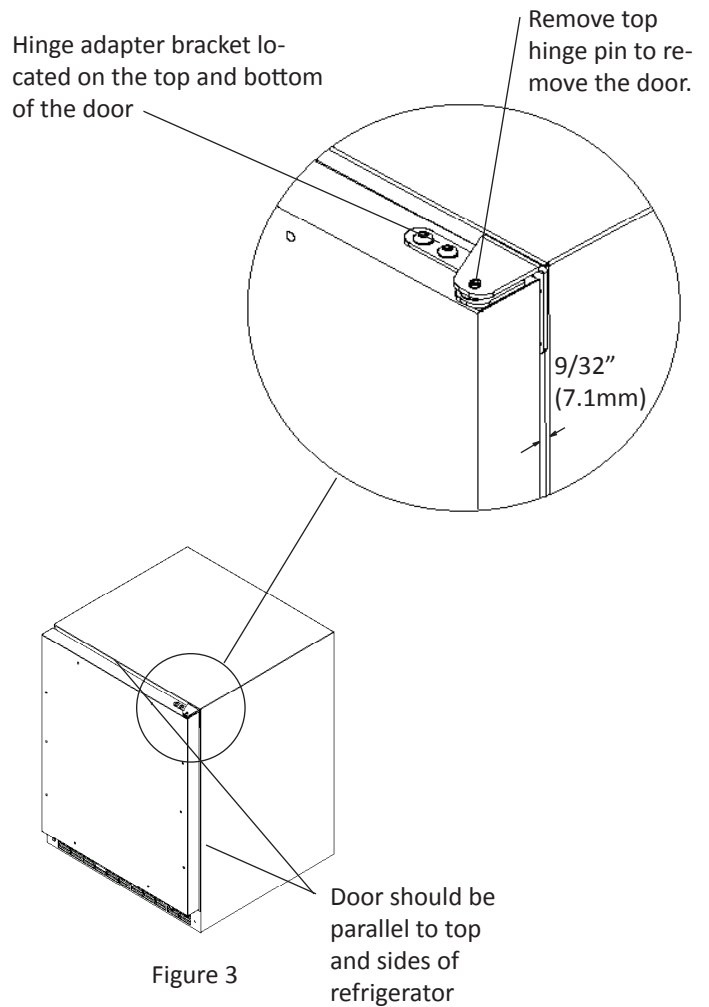
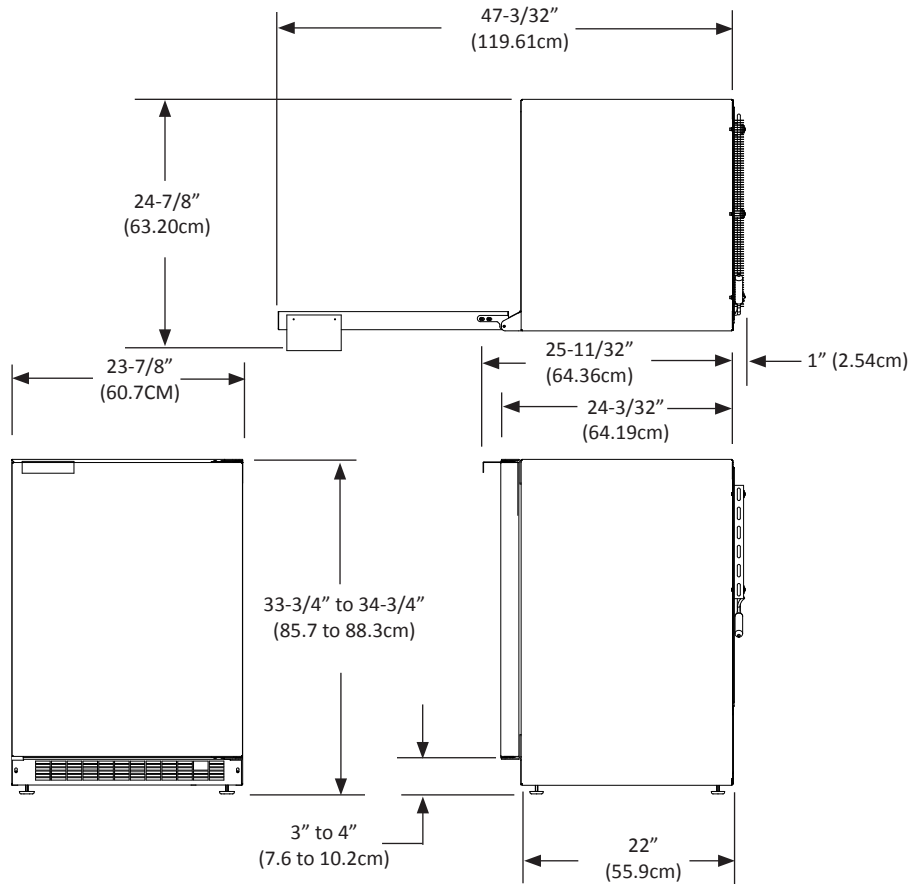
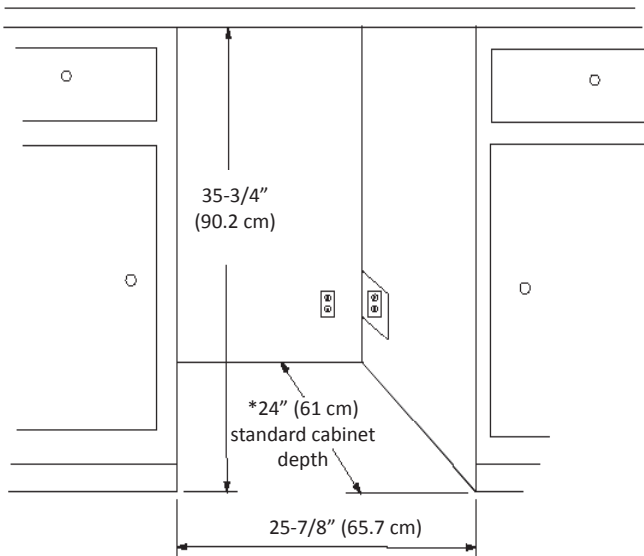

Figure 3

## DIMENSIONS FOR 4EAF, 6EAR, 6ERF WITH SOLID DOOR



## ROUGH IN OPENING FOR 4EAF, 6EAR, 6ERF WITH SOLID DOOR



\* Depth dimension may vary depending on each individual installation. A minimum depth of 27-1/2" (69.9cm) is required with ample provision for wiring.

## ADJUSTING THE TEMPERATURE CONTROL

### Adjusting the temperature control

The temperature control shaft is located behind the front grill on the right side of the cabinet. (See Figure 1, on page 4). It can be adjusted with a flat bladed screwdriver.

Initially set the control midway between the turning ranges. Then adjust to the temperature that suits your application. The more the shaft is turned clockwise, the cooler the temperature. To turn off the refrigeration system turn the shaft counterclockwise until it stops.

### Defrosting Instructions

Model 6EAR (all-refrigerator) automatically defrosts its cooling plate during each compressor off cycle. No manual defrosting is required.

The combination refrigerator / freezer (6ERF) and the freezer (4EAF) are manual defrost models and require occasional defrosting. Never use a scraper or any tool that might scratch or pierce the cooling plate. Follow these steps whenever 1/4 inch or more of frost accumulates.

1. Set the temperature control to the "OFF" position by turning the temperature control shaft counterclockwise until it stops. This will turn off the refrigeration system.
2. Remove the contents from the unit.
3. Place pans of hot water on the cooling plate if you wish to speed up defrosting.
4. Wipe out the interior and replace the contents.
5. Set the temperature control to the desired level.

### In the Event of a Power Failure

Minimize the number of door openings to prevent a gradual rise in temperature while the power is off.

NOTE: If a power interruption occurs, the unit may take five (5) to ten (10) minutes to restart.

### Energy Saving Tips

The following suggestions will minimize the cost of operating your refrigeration appliance.

1. Do not install your appliance next to a hot appliance, (cooker, dishwasher, etc.). heating air duct, or other heat sources.
2. Install product out of direct sunlight.
3. Assure the toe grille vents at front of unit beneath door are not obstructed and kept clean to allow ventilation for the refrigeration system to expel heat.
4. Plug your appliance into a dedicated power circuit. (Not shared with other appliances).
5. When initially loading your new product, or whenever large quantities of warm contents are placed within refrigerated storage compartment, minimize door openings for the next 12 hours to allow contents to pull down to compartment set-point temperature.
6. Maintaining a relatively full storage compartment will require less appliance run time than an empty compartment.
7. Assure door closing is not obstructed by contents stored in your appliance.
8. Allow hot items to reach room temperature before placing in product.
9. Minimize door openings and duration of door openings.
10. Use the warmest temperature control set-point that meets your personal preference and provides the proper storage for your stored contents.
11. For wine storage products:
  - a. When serving temperatures are not required, return the compartment(s) set-point to the ideal red and white wine long term storage temperature of 13°C / 55°F.
  - b. For Dual-Zone product with two (2) independent temperature controlled compartments, use the lower compartment for the coldest storage / serving temperature, (i.e.- red wines on top, white wines in lower).
12. Minimize use of display lighting option on glass door products, (light stays on with door closed).
13. When on vacation or away from home for extended periods, set the appliance to warmest acceptable temperature for the stored contents.
14. Set the control to the "off" position if cleaning the unit requires the door to be open for an extended period of time.
- 15) Annually clean condenser heat exchange coil located on the back of the unit. See page 8.

## CARE AND CLEANING

---

### Cleaning instructions

#### Condenser

The condenser tubing or fins behind the cabinet do not require frequent cleaning; however, satisfactory cooling depends on adequate ventilation over the condenser. Be sure that nothing obstructs the air flow openings in the front grill (see Figure 1). At least once or twice a year brush or vacuum the condenser for efficient performance.

#### CAUTION

Use care when cleaning the condenser. The condenser fins are sharp and could cause cuts.

#### Cabinet

The painted cabinet can be washed with mild soap and water and thoroughly rinsed with clear water. NEVER use abrasive scouring cleaners.

#### Interior

Wash interior compartment with mild soap and water. DO NOT use an abrasive cleaner, solvent, polish cleaner, or undiluted detergent.

#### Door Gasket

The vinyl gasket may be cleaned with mild soap and water, a baking soda solution, or a mild scouring powder.



# TROUBLESHOOTING YOUR REFRIGERATOR

## Before You Call for Service

If the unit appears to be malfunctioning, read through this manual first. If the problem persists, check the troubleshooting guide below. Locate the problem in the guide and refer to the cause and its remedy before calling for service. The problem may be something very simple that can be solved without a service call. However, it may be required to contact your dealer or a qualified service technician.

## WARNING

**Electrocution Hazard** - Never attempt to repair or perform maintenance on the unit until the main electrical power has been disconnected. Turning the unit control "OFF" does not remove electrical power from the units wiring.

Problem	Possible Cause	Remedy
Unit not cold enough.	<ul style="list-style-type: none"><li>Control set too warm.</li><li>Airflow to front grille blocked.</li><li>Excessive usage or prolonged door openings.</li><li>Door gasket not sealing properly.</li></ul>	<ul style="list-style-type: none"><li>Adjust temperature colder. See page 7 for adjusting thermostat. Allow 24 hours for temperature to stabilize.</li><li>Airflow must not be obstructed to front grille. See "clearances" on page 4.</li><li>Allow temperature to stabilize for at least 24 hours.</li><li>Check door alignment and/or adjust or replace door gasket.</li></ul>
Unit too cold.	<ul style="list-style-type: none"><li>Control set too cold.</li></ul>	<ul style="list-style-type: none"><li>Adjust temperature warmer. See page 7 for adjusting thermostat. Allow 24 hours for temperature to stabilize.</li></ul>
Noise or Vibration.	<ul style="list-style-type: none"><li>Unit not level.</li></ul>	<ul style="list-style-type: none"><li>Level unit, see "Leveling Legs" on page 4.</li></ul>
Unit will not run.	<ul style="list-style-type: none"><li>No power to unit.</li></ul>	<ul style="list-style-type: none"><li>Circuit breaker tripped, reset circuit breaker.</li></ul>

## OBTAINING SERVICE

---

### If Service is Required:

- If the product is within the first year warranty period please contact your dealer or call AGA MARVEL Customer Service at 800.223.3900 for directions on how to obtain warranty coverage in your area.
- If the product is outside the first year warranty period, AGA MARVEL Customer Service can provide recommendations of service centers in your area. A listing of authorized service centers is also available at [www.agamarvel.com](http://www.agamarvel.com) under the service and support section.
- In all correspondence regarding service, be sure to give the model number, serial number, and proof of purchase.
- Try to have information or description of nature of the problem, how long the unit has been running, the room temperature, and any additional information that may be helpful in quickly solving the problem.
- Table A is provided for recording pertinent information regarding your product for future reference.

For Your Records	
Date of Purchase	
Dealer's name	
Dealer's Address	
Dealer's City	
Dealer's State	
Dealer's Zip Code	
Appliance Serial Number	
Appliance Model Number	
Date Warranty Card Sent (Must be within 10 days of purchase).	

Table A

# COMMERCIAL PRODUCT WARRANTY

## Entire Product - One Year Parts and Labor Warranty

AGA MARVEL warrants to the original purchaser that it will supply all necessary parts and labor to repair or replace in the end user's establishment, any component which is found by an authorized representative of AGA MARVEL to be defective in materials or workmanship, subject to the conditions and exclusions stated below, for a period of one year from the date of purchase by the end user.

## Refrigeration System - Additional Second Through Fifth Year Parts Only Warranty

During the four years following expiration of the one year limited warranty, AGA MARVEL warrants to the original purchaser that it will supply replacement parts for the hermetically sealed refrigeration system which consists of the compressor, evaporator, condenser, drier, and connecting tubing that are found to be defective in workmanship or materials. Other parts, labor costs, and freight charges are the responsibility of the end user.

If AGA MARVEL is unable to repair or replace the defective product or component, AGA MARVEL shall issue a credit to the buyer for all or part of the purchase price, as AGA MARVEL shall determine. The repair, replacement, or payment in the manner described above shall be the sole and exclusive remedy of buyer for a breach of this warranty.

Buyer must give written notice of any alleged defect in the product to AGA MARVEL within 30 days after discovery of the defect by buyer. If notice is not given within such period, any claim for breach of warranty shall be conclusively deemed to have been waived, and AGA MARVEL shall not be liable under these warranties. AGA MARVEL or its agents shall be entitled to examine the product. AGA MARVEL shall have the option of requiring the return of the defective component, transportation prepaid, to establish the claim. The acceptance by AGA MARVEL of any component returned shall not be deemed an admission that the product is defective or in breach of any warranty and, if AGA MARVEL determines that the product is not defective, the component shall be reshipped to the buyer at the buyer's expense. No component will be returned to AGA MARVEL without its prior consent.

The above warranties do not cover:

- Shipping costs of replacement parts or returned defective parts.
- Customer education or instructions on how to use the refrigerator/freezer.
- Any content loss, or incidental or consequential damage or loss due to product failure.
- Removal or installation.

Nor do the above warranties cover failure of this product or its components due to:

- Transportation, damage sustained in transit, or subsequent damages.
- Use in hostile environments or use for storage of contents hostile to the product.
- Improper installation, misuse, abuse, accident, or alteration, use on wiring not conforming to electrical codes, low voltages, failure to provide necessary maintenance, or other unreasonable use.
- Parts or service not supplied or designated by AGA MARVEL.

The above warranties also do not apply if:

- The original bill of sale, deliver date, or serial number cannot be verified.
- The refrigeration equipment is not in the possession of the original end use purchaser.

**The warranties set forth herein are the only warranties extended by AGA MARVEL and are in lieu of all warranties, express, implied, statutory, or otherwise. In particular, AGA MARVEL makes no warranty of merchantability or fitness for a particular purpose.**

AGA MARVEL's liability for any defect in the product shall not exceed the purchase price of the product. **AGA MARVEL shall have no liability for consequential damages of any kind whatsoever, including, but not limited to, personal injury, property damage, lost profits, or other economic injury due to any defect in the product.**

No person, firm, or corporation is authorized to modify, expand, or extend these warranties, to waive any of the limitations or exclusions, or to make any other warranty or assume any other obligation for AGA MARVEL. These warranties apply only to products used in any of the fifty states of the United States and the District of Columbia.

To obtain performance of this warranty, report any defects to:

**AGA MARVEL**  
1260 E. VanDeinse St.  
Greenville MI 48838

Phone: 616.754.5601  
Toll-Free: 800.223.3900



[www.agamarvel.com](http://www.agamarvel.com)

**AGA MARVEL**  
1260 E. VanDeinse St.  
Greenville MI 48838

800.223.3900

41004297 Rev G  
6/7/12

All specifications and product designs subject to change without notice. Such revisions do not entitle the buyer to corresponding changes, improvements, additions, replacements or compensation for previously purchased products.